

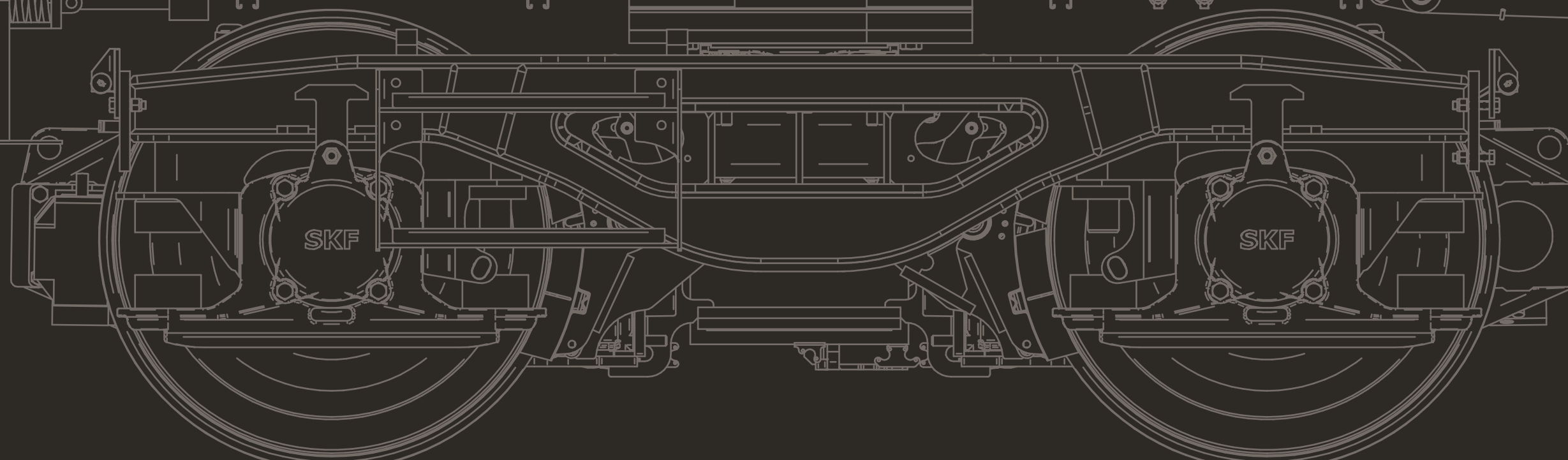

Metropolitano de Lisboa

Assinatura do contrato
para aquisição
de **Máquina de Esmerilagem**
de Carril de Rolamento

30.abr.2021

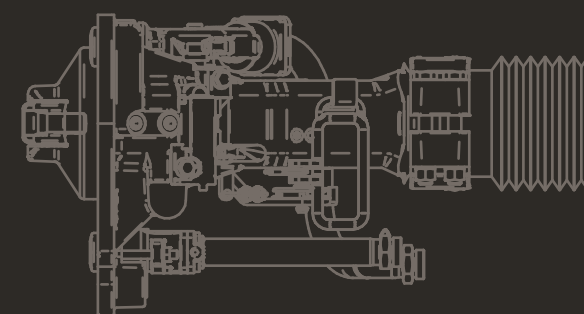

A esmerilagem consiste na **abrasão** das superfícies do carril.



Os rolos de esmerilagem são **pressionados contra o carril** enquanto giram sob os seus eixos a alta velocidade.

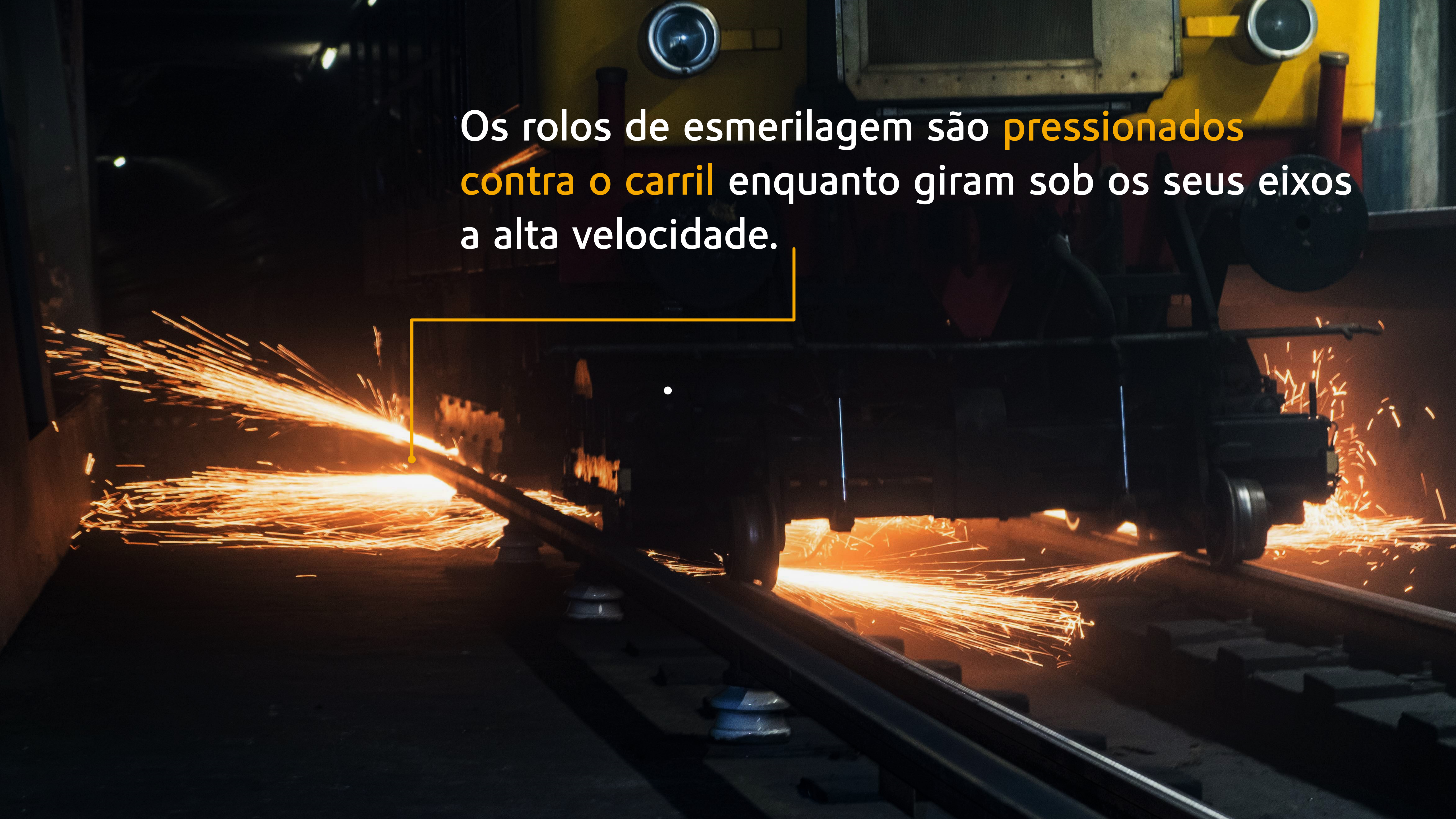

A esmerilagem é necessária para **evitar o desgaste** causado pelo contacto entre a roda e o carril.



Esmeriladora atual

No ML há

44

anos

Faz a manutenção de

124

km de via simples

É utilizada

124

noites por ano

São precisos

24

meses para efetuar
a esmerilagem
em toda a rede

Esmeriladora futura



Esmeriladora futura



Contactos para informações adicionais

Helena Taborda	962 408 939	helenataborda@metrolisboa.pt
Gonçalo Santos	961 571 727	goncalosantos@lpmcom.pt
Patrícia Fernandes	939 348 773	patriciafernandes@lpmcom.pt



Metropolitano de Lisboa

SKF